

1. Advanced Accident Prevention System Using IOT

Abstract: Fingerprint identification is one of the most popular and reliable personal biometric identification methods. By using this biometric authentication, we can prevent non-licensees from driving and therefore causing accidents. The proposed system consists of a smart card capable of storing the fingerprint of particular person. While issuing the license, the specific person's fingerprint is to be stored in the card. Vehicles such as cars should have a card reader capable of reading the particular license. The same automobile should have the facility of fingerprint reader. A person, who wishes to drive the vehicle, should insert the smartcard in the vehicle and then swipe his/her finger. If the fingerprint matches with the fingerprint stored in the smart card then it goes for alcohol detection and seatbelt checking. After passing all authentications, the vehicle will be ignited. The vehicle will not be ignited, if any one of the authentications fails and will not proceed the next step. This increases the security of vehicles and also ensures safe driving by preventing accidents. The prototype of the ignition system is used by the Master controller (Cortex M3 based Micro controller) is implemented along with the vehicle prototype is developed and the results are attached.

2. Agri-Moistio Meter Soil & Crop Health Tracker

Crop specific Soil health management in agriculture land is a very tedious task, as there are sensors for soil moisture measurement and Tesnsiometer in the market, but they measure the soil moisture at the specific area inserted inside the land. As we know for any crop, its base of the roots are more than a feet from the soil surface. Therefore, the current devices or techniques do not provide Complete and continuous information about moisture content from soil surface to base of the roots. Therefore, in our proposed project we design Agri-Moistiometer device, which keeps track of moisture levels at different levels of the soil from surface up to the roots zone by dividing different layers of the soil from top surface to bottom of the crop roots. This device will give the difference in soil moisture contents at various layers from top surface to bottom of the roots, which in-tern makes it easy to predict water holding capacity of the soil, amount of water should be supplied and when to supply the water. Apart from moisture contents, this device measures soil temperature and soil PH levels.

3. Animal Detection System For Crop Protection

Abstract: The main aim of our project is to protect the farmland from animals. Wild animals are special challenge for the farmers throughout the world. Animals like wild pigs, elephants, monkeys etc... Causes serious damage to crops. In this project a surveillance camera and GSM module are used. The farmer can check the intrusion of animals and people in his agricultural field and can toggle between few options allowed in order to scare the animals or human away from his field, without the farmer presence in the field. The farmer can control it from a remote area. In this work we are presenting a practical procedure toward them off, by creating a system which studies the behaviour of the animals and human, detects and creates the different sound that irritates the animals or humans and also alerts the authorized person by sending a voice message.

4. Automatic Braking in Vehicles When An animal or Speed Breaker Appears

Abstract: Animals death rate due to accidents is drastically increased because vehicles usage is increasing day by day. Due to brake failure so many accidents are occurring so when we control the brake by automatically we can reduce the effect of accidents.

An Ultrasonic setup is placed in front of vehicle and that setup consists of an emitter and a receiver. Ultrasonic emitter always emits the ultrasonic waves, whenever an obstacle is detected then wave gets reflected and receiver receives the signal. Reflected wave sends the signal to the Arduino UNO from that based upon distance of object it actuates the buzzer or brakes.

Brakes are actuated by using Solenoid valve. Solenoid valve operated by electrical signal and it actuates brakes by using pneumatics. UBS car provides the glimpse into the future of automotive safety. By UBS system we can prevent more accidents and save more lives.

5. Automatic Lameness Detection In Cattle

Abstract: Identification of cow lameness is important to farmers to improve and manage cattle health and welfare. No validated tools exist for automatic lameness detection. In this research, we aim to early detect the cow lameness by identifying the instantaneous fundamental gait harmonics from low frequency (16Hz) acceleration signals recorded using leg-worn sensors. Methods: A triaxle accelerometer has been worn on each cow leg. Synchro squeezed wavelet transform (SSWT) has been applied to acceleration signals to generate the initial time-frequency spectrum related to the gait. This spectrum is given as an input to a designed deep neural network including time-frequency based long short-term memory (LSTM) to estimate instantaneous frequencies at each time point. An inverse SSWT (ISSWT) is then used to recover the gait harmonic and to estimate an enhanced spectrum. Results: Validation of instantaneous frequencies has been provided for each cow leg (combined signals from 23 cows) and the time-series cross validator across the three folds are provided. The average of mean squared errors in frequencies across 3 folds for each leg is obtained as 0.036, 0.033, 0.044 and 0.042 for left-front, right-front, right-back and left-back legs, respectively. Conclusion: Estimation of instantaneous gait frequencies is proved useful for identification of cow gait phases, lameness detection, accurate estimation of gait speed, coherency in movement among the legs and identification of non-gait episodes. Moreover, the proposed method can be used as a new frequency ridge estimation method exploiting SSWT for many other applications.

6. Cloud Based Intelligent System For Aquaculture

Abstract: Water is polluted due to use of pesticides, fertilizers, industrialization, urban development etc. Aquaculture is farming of fish, aquatic plants, molluscs, algae and other organisms. so it involves cultivation fresh and salt water population.

Due to underdevelopment of economy in marine species, the demand for high quality protein, for breeding, raising and harvesting fish encouraged aqua culturists to culture fishes.

But for the traditional farmers, they face problems when monitoring water quality.

So by using cloud service, IFTTT (If This Then That), think speak, sensor modules, local network system and a visualization data, we can able to monitor data via the internet. This makes the aquaculture more customizable and expandable.

7. Deep Learning Supervision For Covid 19 Infection Detection And Classification From Ct Images

Abstract: 3D volumetric imaging has become a valuable tool for diagnosis and prognosis of COVID-19 patients. In this project, we propose new method for detecting and classifying COVID-19 infection from 3D volumetric lung images. For the detection and classification process, we have used 3D volumetric image processing and deep learning techniques respectively

8. Detecting And Predicting Emerging Disease In Poultry With The Implementation Of New Technologies And Big Data: A Focus On Avian Influenza Virus

Abstract: Future demands for food will place agricultural systems under pressure to increase production. Poultry is accepted as a good source of protein and the poultry industry will be forced to intensify production in many countries, leading to greater numbers of farms that house birds at elevated densities. Increasing farmed poultry can facilitate enhanced transmission of infectious pathogens among birds, such as avian influenza virus among others, which have the potential to induce widespread mortality in poultry and cause considerable economic losses. Additionally, the capability of some emerging poultry pathogens to cause zoonotic human infection will be increased as greater numbers of poultry operations could increase human contact with poultry pathogens. In order to combat the increased risk of spread of infectious disease in poultry due to intensified systems of production, rapid detection and diagnosis is paramount. In this review, multiple technologies that can facilitate accurate and rapid detection and diagnosis of poultry diseases are highlighted from the literature, with a focus on technologies developed specifically for avian influenza virus diagnosis. Rapid detection and diagnostic technologies allow for responses to be made sooner when disease is detected, decreasing further bird transmission and associated costs. Additionally, systems of rapid disease detection produce data that can be utilized in decision support systems that can predict when and where disease is likely to emerge in poultry. Other sources of data can be included in predictive models, and in this review two highly relevant sources, internet based-data and environmental data, are discussed. Additionally, big data and big data analytics, which will be required in order to integrate voluminous and variable data into predictive models that function in near real-time, are also highlighted. Implementing new technologies in the commercial setting will be faced with many challenges, as will design and operating predictive models for poultry disease emergence. The associated challenges are summarized in this review. Intensified systems of poultry production will require new technologies for detection and diagnosis of infectious disease. This review sets out to summarize them, while providing advantages and limitations of different types of technologies being researched.

9. Educational Toy for Kids

Abstract: This project mainly deals with the design of an attractive toy for children which provides both fun and ensures basic learning for children. The best way to make children learn is through attractive toys. Encouraging children to play with educational toys can help in their intellectual and motor development. Introducing educational and physical activity toys at an early stage of a child's development years has seen to enhance their senses, spark their imagination and enhance their social skills. Educational toys can be ideal for both quiet and independent learning as well as group and social work. The concept of an e- toy refers to a technologically developed physical toy designed for serving a meaningful purpose. This project presents the design of an affordable, smart, reliable and portable educational toy. The designed system is developed to teach alphabets, to teach names of objects and even help learning through rhymes. The system takes the input through a RFID scanner and gives a speech output. It is believed that by implementing this system in schools and homes for pre-school children, enhanced improvement in children's cognitive and learning skills is observed. It is designed in an attractive manner so that children will find it fun and interesting while learning. It is a very useful toy for teachers also to make their teaching more interesting for children.

10. E-PluginSense: Efficient solution for water wastage & utility in residential- Public places

Abstract: Now-a-days we have seen unnecessary water wastage & utility at both residential & public places due to many factors (irresponsibility, ignorance, timely unavailability etc.).

Current problems:

1. Residential places:

- Untimely water supply made it difficult for residents to fetch the water, especially in rural places where farmers & land laborers go for work early morning this leads to wastage of water due to open taps.
- One more major problem is un-uniform water supply to many residents at rural, urban & metropolitan cities due to uneven landscaping. So water utility management based on usage needs a serious attention.

1. In most of the cases, public taps & water supply units have broken/damaged taps leading unnecessary wastage of water.

To address all the above mentioned problems, we propose to design an electronic plug-in device for sensing water supply status, water utility management & controlling the water supply channels automatically. In absence of residents, E-sense device will automate the water supply to underground sumps & overhead tanks based on sensing.

Mainly to address the problem of un-uniform water supply, E-Sense device will measure the water usage of every residents & stores in the database for billing according to the water utility at the end of every month.

11. Fish Disease Detection System In Freshwater

Abstract: The proposed system is designed for automatic detection and classification of fish diseases in freshwater. Our experimental result is indicating that the proposed approach is significantly an accurate and automatic detection and recognition of fish diseases. This study presents fish disease detection based on the K-means and C-means fuzzy logic clustering method to segment the filtering image. Gabor's Filters and Grey Level Co-occurrence Matrix (GLCM) are used to extract the features from the segmented regions. Finally Multisport Vector Machine (M-SVMs) is used for classification of the test image. The proposed system demonstrated a comparison between K-means clustering and C-means fuzzy logic. The proposed methodology gave 96.48% accuracy using K-means and 97.90% using C-means fuzzy logic which is the highest accuracy rate to compare other existing methods. The proposed system has been experimented in the MATLAB environment on infected fish images. It is a challenging task of fisheries farming in Hoar areas and Lake Areas to detect fish diseases initially. The proposed methodology can detect and classify different fish diseases in early stages and also contributes to improved results for fish disease detection.

12. Fusion-Shield Security System

Sandalwood trees are identified for their fragrance and healthful value, due to that they have very best industrial advantage compared to different trees. Government of India promulgated an amendment to encourage private domestication of sandalwood as a means to conserve and enhance the status of this resource. However, in recent years there has been a rise in the range of sandalwood robberies and threats as there's no pertinent answer out there for protecting these sandal wood trees, thus, making them endangered. This paper proposes a protection mechanism that makes use of fusion technique of combining fiber optic sensors along with image Recognition algorithms.

CHAIN LINK fence is the most primitive and trusted security systems to protect from the unwanted visitors who are trying to steal our green cover. So in our Fusion shield security system we integrate fiber optic sensors with this chain link fence. Whenever intruder tries to cut or climb the fencing there is a change in the way that light is propagated down the core of the fiber. Any movement of the optical fiber causes a change in what is called the speckle pattern. Our detector registers a change in the speckle pattern. We employ a sophisticated digital-signal processor that runs many algorithms to determine if a signal is an intruder or environmental background noise, such as wind, lightning. There are several calibration parameters that tune the DSP to respond correctly to the intruder arrival and not to the external environmental factors. Then this "exact intrusion location" updated automatically and image recognition cameras activated for instantaneous verification, Upon conformation the system provides reliable intrusion alarms help users make prompt decisions to safeguard the sandal wood timber.

13. Green House Monitoring and Control System Using IOT

Abstract: Greenhouse effect is a natural phenomenon and Beneficial to human being. Numerous Farmers fail to get good profits from the greenhouse crops for the reason that they can't manage two Essential Factors. 1. Plant Growth 2.productivity

To overcome such challenges this Green House Monitoring and control system comes to rescue. This project demonstrates the design and implementation of a various sensors for green house monitoring and controlling.

This greenhouse control system is powered by at mega 328 microcontrollers it consists temperature sensor, light sensor, soil moisture sensors, LDR sensor, LCD display module, 12v Dc fan, Bulb and pump.

Working: Temperature sensor senses the level of temperature. If it goes high DC fans gets ON and when the temperature goes low the fan gets OFF.

Soil moisture sensor, senses the water level as the level decreases the pump gets ON. In the absence of light, the LDR sensor senses and the bulb start glowing.

This system helps in monitoring and controlling climatic conditions that are favourable for the cultivation of particular plant. By using this system, crop growth can be improved along with maximized yield, irrespective of the weather conditions.

14. Indoor Farming Hydroponic Plant Grow Chamber

Abstract: In order to feed future, Indoor farming is the best choice where we need less land to cultivate more. Farming and Gardening can be done in better way using smart technology. Hydroponics is an emerging soil free agriculture, wherein plants are grown in nutrient solutions without soil.

Need: Urbanization, natural disaster, climate change, indiscriminate use of chemicals and pesticides that deplete the land fertility are restricting the soil cultivation of crops.

Our solution: Smart grow chambers that monitor and supply the plants with all necessary ingredients for proper growth. So here we design a 3 layer indoor farming unit using programmable hydroponic system.

Our system makes use of smart water supply and draining system coupled with air flow and artificial sunlight for a perfect grow environment. Our system would allow for all weather indoor farming as and when needed for organic food grown indoors. Thus, the system provides a fully automatic method to monitor and bolster plant growth by ensuring perfect plant growth conditions as programmed by user.

15. IoT AND SOFTWARE Based Soil Nutrient Monitoring & Analysis System

Abstract: In this project, we will learn about IoT Based Soil Nutrient Monitoring & Analysis systems using Arduino & ESP32. Soil is the base of agriculture. Soil provides nutrients that increase the growth of a crop. Some chemical and physical properties of soil, such as its moisture, temperature, soil nitrogen, phosphorous & potassium content heavily affect the yield of a crop. These properties can be sensed by the open-source hardware, and they can be used in the field. In this project, a soil Nutrient monitoring & analysis system is proposed in which the farmer will be able to monitor soil moisture, soil temperature, and soil nutrient content like Nitrogen, Phosphorous & Potassium. The farmer can monitor all these parameters wirelessly on a mobile phone or the PC System. On the basis of analysis, my software is going to match all the nutrient data with previously upload data. From that we will able to know what

are merits and demerits of that soil and what type of crop we can able to grow their and fertilizer we have to give to crop. They can also able to give proper irrigation to their crop as per weather forecasting.

16. IOT Based Monitoring System For Comatose Patients

Abstract: As we know coma is a state of unconsciousness in which patient cannot feel or respond to the pain, light or sound, it does not initiate volunteering any actions. Patients in a coma state need to have continuous update of blood pressure, temperature, humidity, and urine level. Doing this manually can become almost impossible to keep updates of multiple patients at the same time. In order to address this situation, our system comes to the rescue; this system will collect the information of patients with the help of sensors. These sensors use WIFI to communicate this information to the internet. This system is powered by the raspberry pi it includes a blood pressure monitoring unit and an ultrasonic sensor to check urine, temperature sensor, motion sensor, and an LCD display.

17. IOT Based Person/Wheelchair Fall Detection....

Abstract: When it comes to old age, it becomes necessary to monitor our old ones for health and safety. Due to weakness and weakjoints they have a great risk of falling down. Now it is important to know if oldness has fallen so that he or she can helped him on time. Also people on wheelchair need to be checked for fall detection.

The System uses accelerometer and gyro sensor to detect person movements, it can be mounted on persons hand or wheelchair for detection. The sensor is connected to a microcontroller in order to constantly transmit the acceleration data. Now the system keeps monitoring for fall detection and abrupt movement changes in person.

A Sudden abrupt change with jerk in the system is treated as fall. Now in case the person did not fall and alarm was false, the system allows to snooze the alert if person presses snooze button in 5 seconds. If person does not press the snooze, system detects person has fallen and automatically triggers alert through Wi-Fi connection.

18. IOT Based smart farming

Abstract: Smart agriculture is a farming system that uses IoT technology. This emerging system increases the quantity and quality of agricultural products. IoT devices provide information about the nature of farming fields and then take action depending on the farmer's input. In this project, an IoT-based advanced solution for monitoring the soil conditions and atmosphere for efficient crop growth is presented. The developed system is capable of monitoring temperature, humidity, soil moisture level using Arduino Uno, and several sensors connected to it. Also, the details can be accessed through the farmer's mobile phone using Think Speak website about the environmental condition of the field.

19. IOT Flood Monitoring & Altering System

Abstract: FLOODING is usually brought on by an increased quantity of water in a water system, like a lake, river overflowing. On occasion a dam fractures, abruptly releasing a massive quantity of water. The outcome is that a number of the water travels into soil, and 'flooding' the region. Rivers are involving river banks, in a station.

Flood predictions need information like: The speed of change in river stage on a real-time basis, which may help indicate the seriousness and immediacy of this threat. Understanding of the form of storm generating the moisture, such as length, intensity and areal extent, which is valuable for discovering potential seriousness of flood. In this system we make use of a raspberry pi with water sensors, rain sensors to predict flood and alert respective authorities and sound instant alarm in nearby villages to instantly transmit information about possible floods using IOT. The water sensors are used to measure water level of 3 different locations. Also 3 different rain sensors are used to measure rain level of those 3 areas. These sensors provide information over the IOT using Raspberry Pi. On detection of conditions of flooding the system predicts the amount of time it would take to flood in a particular area and alerts the village/area that could be affected by it. The system also calculates the time it would take for flood to reach them and provide a time to people.

20. IOT Instant Contactless Covid Testing Booth Automation

Abstract: In view of current pandemic covid testing plays a key role in fighting the pandemic. Covid testing is done in covid testing booths that provide steps

- Registering the person name, contact no address manually
- Taking a swab sample of the person
- Adding the swab sample number against the persons registered details
- Sending the data along with the samples to the lab
- Manually informing (calling/sms) the patient about the result

Now this is a very long process with a lot of manual steps which can lead to human errors because of huge amount of samples coming in for testing. So here we propose a system whereby we automate around 70% of the manual entry work and allow for a single point and fast covid testing system using IOT.

Our system consists of a camera and speaker combination powered by a raspberry pi based controller and operating circuitry. We hereby use a keypad and button interfaced with the controller for test person ease.

The system totally isolates the test person from the user and also makes the process fast and error free by automating registration process too.

With the new system the testing process works as follows:

- No need for separate registration, the system uses camera for instant aadhar card scan registration

- The Test person enters the sample number of the person from inside the booth using provided keypad
- The system uses speaker to inform patient that his test is done and next person to come forward
- The data collected by the time is transferred over to Lab using IOT automatically before next person comes ahead
- The lab in charge can view the no of samples tested in real time and can update sample test results too on IOT server
- When lab in charge updates test result of a sample, a sms is instantly sent to the respective person by the system itself

21. Odor Sense: Sensing Device For Alerting Health Effects Of Odor Pollution

Abstract: Nowadays there is an increased conflict between residents and government bodies /or industries due to unpleasant or offensive odor smells emanating from different sources, interfacing with person's enjoyment of life as they are frequent and persistent

The main concern among all the residents is the health effects of toxic odor gases (like, ammonia, Sulphur dioxide, nitrogen, hydrogen sulfide) released from the waste dumping sites, drainages, food & meat processing industries, etc., causing dreadful diseases to the living beings

Till date very little attention has been paid towards odor pollution issues in India, therefore odor pollution and its problems has become objectionable proportion with the growing population, industrialization, and urbanization.

We propose to design an intelligent (Device) mechanism to

- Measure & monitoring Odor Concentrations i.e. bad Odor coming out of different sources.
- Develop User Interface for providing real time information about the odour concentration levels at the desired source and alerting the health effects and precautionary measures to tackle odor pollution.

22. Plugin Sense: Efficient solution for water wastage & utility in residential-Public places

Abstract: Now-a-days we have seen unnecessary water wastage & utility at both residential & public places due to many factors (irresponsibility, ignorance, timely unavailability etc.).

Current problems:

1. Residential places:
 - Untimely water supply made it difficult for residents fetch the water, especially in rural places where farmers & land labors go for work early morning this leads to wastage of water due to open taps.

- One more major problem is un-uniform water supply to many residents at rural, urban & metropolitan cities due uneven landscaping. So water utility management based on usage needs a serious attention.

2. In most of the cases, public taps & water supply units have broken/damaged taps leading unnecessary wastage of water.

To address all the above mentioned problems, we propose to design an electronic plug-in device for sensing water supply status, water utility management & controlling the water supply channels automatically. In absence of residents, E-sense device will automate the water supply to underground sumps & overhead tanks based on sensing.

Mainly to address the problem of un-uniform water supply, E-Sense device will measure the water usage of every residents & stores in the database for billing according to the water utility at the end of every month.

23. Power Generation Using Speed Breakers

Abstract: In the present situation power becomes basic need for human life. Energy is responsible for major developments of any country's economy. Conventional energy sources generate most of the energy of today's world. But the population is increasing day by day and the conventional energy sources are diminishing. Moreover, these conventional energy sources are polluting and responsible for global warming. So, nonconventional sources are needed to be developed for power generation which are clean, environment friendly and sustainable.

Here, is a renewable non-conventional energy source being a proposal which is based on speed breaker mechanism. The main aim is to enlighten the streets utilizing the jerking pressure which is wasted when the vehicles passes over speed breaker on roadside. In this way energy generated is tapped by the moving vehicles and produce power by using the speed breaker as power generating unit. The kinetic energy of the moving vehicles can be converted into mechanical energy through rack and pinion mechanism and this mechanical energy will be converted to electrical energy using generator which will be used for lighting the street lights. Therefore, by using this mechanism a lot of energy is saved which is used can fulfil our future demands.

24. Prevention of Malpractice in Voting System

Abstract: Usually voting is done by casting their vote in polling booth. The main aim of this project is to make voting secure using fingerprint verification and also to reduce malpractices before voting. The details of the voter along with their fingerprint is stored in database. If the fingerprint matches with the stored fingerprint, the system checks the aadhar number of the user and if authenticated, it checks if multiple votes have been cast. If the fingerprint matching is not correct "Matching failed" message will be displayed and if aadhar number is not correct, then "Aadhar not match" message will be displayed.

The Arduino controller used in this project. Fingerprint is used to authenticate the user. There is at least a slight difference between the fingerprints of each person. When a malpractice occurs, "Already voted" message will be displayed. The Arduino IDE is used for programming the board and cloud is used to store the data of voters belongs to particular booth. System provides an alert on malpractice and only

an authorized voter can cast the vote. This project safeguards the citizen's right to vote and guarantee fair election.

25. Rain Sensing Automatic Car Wiper

Abstract: Today's car wipers are manual systems that works on the principle of manual switching. So here we propose an automatic wiper system that automatically switches ON detecting rain and stops when rain stops. Our project brings forward this system to automate the wiper system having no need for manual intervention. For this purpose we use rain sensor along with microcontroller and driver IC to drive the wiper motor.

Our system uses rain sensor to detect rain, this signal is then processed by microcontroller to take the desired action.

The rain sensor works on the principle of using water for completing its circuit, so when rain falls on it its circuit gets completed and sends out a signal to the microcontroller. The microcontroller now processes this data and drives the motor IC to perform required action. The motor driver IC now drives a servomotor to simulate as a car wiper.

26. Single Window Smart Electricity Metering and Automatic Billing System

Current electricity metering system involves manual and prepaid meters. This current system cannot overcome electricity theft as they are installed at every houses with complex meters (uses many resources).

We propose Single window smart electricity metering and automatic billing system, in which the metering will be implemented at electric Pole having Single Window, based metering covering multiple houses at the Pole. So this will Innovative solution avoids power theft completely and metering system uses very less resources costing 1/10th of the current system. Single Window system combines multiple power plugs with internal power measurement unit. Dynamic power consumption by every household data shall be stored and uploaded to Cloud and then the real-time power usage and billing information ca be accessed via user-friendly mobile application.

27. Site Specific Crop Monitoring System Through Wireless Technology

Abstract: This paper presents the design and implementation of a wireless sensor network on agricultural environment to monitor environment conditions through (nRF24L01+wireless module) technology and monitoring humidity, temperature, and ambient light intensity and soil moisture levels. Monitoring these parameters is one of the most important aspects in agricultural production that has its direct impact on the productivity and maintenance of field crop. By various diseases caused improper maintenance of some climatological conditions. Moreover, monitoring appropriate environmental parameters required for the high yield of crop production on a given farmland among different technology for crop monitoring wireless sensor network are process the data in the agriculture domain with low cost and low energy power. This cost effective technology to improve its production and enhance agricultural yield.

28. Smart Pesticide Sprayer Robot For Agriculture Using Gsm Module

Abstract: Farmer is the back bone of our country. Our country is an agrarian country with around 70% of its depending directly or indirectly upon agriculture. The farmer will grow multiple plants in their field. But some technical abilities along with technological assistance are required to achieve high output and excellent quality.

For agriculture based country like India, control of pest in the crop field is an important factor. In order to increase the efficiency and effectiveness and to reduce the manual involvement of spraying mechanism, an automated sprayer is needed. Efforts have been made to automate pesticides spraying by using dc pump and battery, but effective usage still a challenge with automatic path identification and charging of battery.

The technological solution to the human health hazards involved in spraying of potentially toxic chemicals in the confined space of an atmosphere. This achieved by the design and construction of an autonomous mobile robot for use in pest control and disease prevention applications in commercial farm. The effectiveness of this platform is shown by the ability to successfully navigate itself down rows of farm, spray the pesticides effectively while the farmer controls it from a far distance. And this pesticide spraying system effectively covers the plants evenly with spray in the set dosages.

29. Smart Toilet For Automatic Flushing

Abstract: In our nation, sanitation has always been a major issue. Most significantly, this issue is not just concentrated to the rural areas but is also wide spread in urban and semi urban areas. People do not show the same level of concern when it comes to keeping the public sanitation systems clean as they show towards the ones at their homes.

However in India, the scenario of public toilets is still dismal. One of the reasons for this is that the people do not bother to clean up after they use the toilet. These places are thus the breeding grounds of bacterial germs like Escherichia coli and many deadly diseases. Many people sometimes prefer discomfort to using these toilets. Looking at such troubles, the decision to construct a self-flushing toilet was made that simply utilizes the weight of the person using it as its working mechanism. The system consists of a platform supported on springs and the lever arrangement that flushes after use. The lever is pivoted in such a way that it will lower itself when weight is applied downward and when the load is released, this will strike the flush and hence in this way water is flushed out to clean the toilet. The design is robust and cost effective. Sensors or any kind of electrical transducers are not required in the construction of these toilets. As the old saying goes "cleanliness is next to godliness", this is a public welfare project which aims to propagate a cleaner and hygienic society and hence, take our nation to the heights of glory

30. Smart Vending Machine for Vegetables and Fruits Using IoT

Abstract: Now days in these fast-moving world appliances which are completely automatic are preferred. This is the biggest advantage of this project. The system is fully controlled by the Arduino automated dispensing machine decentralized fruits and vegetables distribution system that provide computer-controlled storage, dispensing, and tracking of vegetables have been recommended as one potential mechanism to improve efficiency and they are now widely used in many departments store.

The proposed system displays preserved items and quantity of items in the machine. It accepts digital payments and the packed items get dispensed.

31. Solar Powered Smart Umbrella

Abstract: With the increase in Ozone layer depletion, UV Rays coming from sun have direct skin effect and more importantly, UV index levels are generally unknown to everyone.

We propose to develop multipurpose UV umbrella to protect common person, farming labours, street vendors, construction workers against harmful effects of UV radiation from Sun.

It has Unique feature of alerting UV index information if the value reaches its limit (i.e. high, very high & extreme) and the same data will be uploaded to the IOT Cloud and also provides additional features like emergency light, cooling fan, and emergency charging ports for electronic gadgets. This smart umbrella connects with a weather forecast service and shares weather information collected from the server to let users through user-friendly Mobile application. It also has an interesting feature of detecting air contaminants present in the atmosphere and alerts the user.

32. Under Ground Radar

Abstract: Water is the human vital requirement for life; in these days, decreasing of the fresh water increases the importance of the aquifer water. However, Upper Egypt is higher than north Egypt, so the water map continually changes daily, and the aquifer water is deeper than 10 m. The ground penetrating radar (GPR) system is used for underground water detection. GPR is a promising technology to detect and identify aquifer water or non-metallic mines. One of the most serious components for the performance of GPR is the antenna system. The technology of the remote sensing and radar is rapidly developing, and it has led to the ultra-wideband electronic systems. All of these factors, such as miniaturized, low cost, possible compromise solution between depth and resolution, scanning in real time, easy to interpret, and decreased the false alarm, are important in designing the ground penetrating system. The electrical properties of the sand and fresh water layers are investigated using laboratory measurement and EM simulation. Different types of antenna may be used in GPR to operate over a frequency range for different penetration depth. Frequency-modulated continuous wave is also used for GPR and for through-the-wall applications. However, most of these kinds of antennas are limited by their large volume for certain applications. Therefore, a compact Vivaldi antenna with EBG and a compact planar printed quasi-Yagi antenna with meandered ground plane are designed to fulfil all above requirement.

33. Vehicle movement based street lights with external light sensing

Abstract: The main aim of this project is that it saves energy by putting on the lights of the system only when the system detects movement of vehicle. The system switches on the street light ahead of the vehicle and switches off the trailing lights simultaneously. In order to detect movement of vehicles, sensors are used. The system automatically puts on the lights that are ahead of the vehicle detected and as soon as the vehicle moves ahead, the trailing lights are switched off. This is better than the existing

system where the street lights are kept on always unlike this system where the street lights are put on only when movement of vehicle is detected which helps in saving lot of energy. During day time these lights are dim as this system has the capability to sense external lights. Thus this system senses the external light and then accordingly puts ON or OFF the street lights. It uses PWM to control the intensity through microcontroller. The sensors sense the vehicle movements and send it to a microcontroller that initiates commands for switching the lights ON/OFF.

34. Water Level Monitoring and Dam Gate Control Over IoT

Abstract: A water level indicator is used to detect and indicate the water level in an overhead tank or any other water container. In this paper, we investigated the design of a water level sensor device using Arduino UNO that can detect the level of water in a water storage system.

This system consists of a level sensor that will detect the level of water and estimate the water inflow rate in a dam and thereby control the movement of gates using IOT in a real-time basis. It offers more flexibility over existing systems.

35. Generation of Electricity By Using Swing

Abstract: Energy is the most important of all resources, while sustainability concept is focuses on the long term survival of communities. Energy need of the world is growing day by day because of consumption of energy at a larger extent with the population growth. Energy resource mainly decides the development of any nation. Hence we need to look at various different means of power generation. This project is about generating power by using a swing, which is used by children for playing that will produce electricity when being used. In such a way that when it swings the mechanical energy is generated and it is converted into electrical energy by a commutator and is stored in a battery. The construction is such a way that, the swinging action makes the horizontal beam rotating through an angle. This shaft is connected to a sprocket to transfer the motion to the free wheel which rotates proportionally with respect to the angle of motion of the swing.

The angular movement is converted into a complete rotation with the help of a chain drive connecting both sprocket and free wheel. The free wheel is connected to a shaft which in turn rotates the spur gear and dynamo arrangement to generate electricity.

36. Generation Of Electricity From Plants

Over the past centuries, world economic growth is inseparable to the ever-expanding use of hydrocarbon energy sources such as petroleum, coal and natural gas. The trend of global economic currently hinges on increasing rates of production of these fuels. However, petroleum oil and gas, and coal are non-renewable energy resources that will cease in the future. Due, in part, to increased concerns over depleting fossil fuel energy, climate change and environmental pollution, researchers around the world have made significant and impactful efforts to exploit new sustainable and environmentally-friendly energy resources.

Bio electrochemical systems, notably microbial fuel cells (MFCs) that can harvest energy from organic wastes through microbial metabolism, have attracted attentions in recent decades as a potential method for clean energy production coupled with the added benefits of bioremediation. The electricity

produced from coal, natural gas and other fossil fuel are non-renewable. The emission during the production of electricity using these sources is harmful to the environment. After some period of time, these sources will become extinct. Hence, we need a more sustainable form of energy. The present work presents some fundamental procedures to harvest weak electricity from living plants. It was done by embedding pairs of electrodes into the plants where electrical energy is harvested by completing the connection with conditioning circuit.

As an attempt made to determine the voltages developed for various plants like aloe Vera, tulasi, spider plant (*Chlorophytum comosum*), and sugar cane. Details of the experimental works are further explained in Section II. Towards the end, the best combination that produces the highest voltage was tested on Light Emitting Diode (LED), its potentiality on low electrical power appliances. And also the stability of the voltage for various combinations was tested to use for further low voltage applications.

37. Savonius Wind Turbine And Solar Panel

Renewable energy sources i.e. energy generated from solar, wind, biomass, hydro power, geothermal and ocean resources are considered as a technological option for generating clean energy. But the energy generated from solar and wind is much less than the production by fossil fuels, however, electricity generation by utilizing PV cells and wind turbine increased rapidly in recent years.

Many of researchers go through various topologies of Solar-Wind hybrid Power generation system that harnesses the renewable energies of Sun and Wind to generate electricity. In this project the electrical energy is generated from Wind mill combined with solar system. Here wind energy is utilized from wind pressure produced due to the vehicle motion on highways and solar energy is harnessed during day time.

By using this we get continuous power. The dynamo is connected to the shaft of the vertical axis wind turbine to generate electricity. The electrical output of vertical axis turbine and the solar system is stored in a battery. This stored energy can be further used for street lighting etc.

38. Fuel From Waste Plastic Through Pyrolysis

Abstract: The first synthetic plastic was invented in 1907 since then it has been proved to be one of the efficient material for storage and handling but it took years to realize that plastic are threat to environment. They become common junk in every corner in the earth some solutions like burning plastic, but this lead to increasing in air and soil pollution. Being invoked by these issue biodegradable plastics is developed in mind 1990's. However nowadays only a small fraction of the existing plastics are recyclable.

The remaining non-degradable plastics in the form of carry bags, construction materials are left unrecycled and become a major concern to the world governments, this lead to the development of plastic pyrolysis. It includes depolymerisation of waste plastics followed by thermal/catalytic cracking. The fuel is obtained further distilled to get different petroleum products.

In this project pyrolysis process is used for depolymerisation were cracking at low temperatures and pressures with (HDPE+LDPE+PP) plastics. Thermal degradation is occurred to separate the hydro carbons

at temperature ranges from 300 to 500 c to obtain the semi solid of the plastic fuel and mix with the diesel and heated with temperature 50 c to separate the waste content in the semi solid and fuel is obtained with different properties and mix blends with diesel. Various properties of fuel like flash point, fire point, density, colour, odour, boiling point, viscosity, are obtained.

39. Arduino Color Based Product Sorter

Abstract: Sorting of products is a very difficult industrial process. Continuous manual sorting creates consistency issues.

Arduino Color Based Object Sorting demonstrates the operations of sorting machines that are commonly used by industries. This project features an Arduino board and a colour sensor that able to organize objects based on color. The physical construction is design in 3D application which exactly fits to the operation.

Physical construction is made of fiberboard cut and glued with respect to the 3D design. The Arduino Nano serves as the primary controller in which the components such as color sensor and servo motors are connected. It analysis the data received from color sensor and then transmit a command to the servo motors. The color sensor is attached facing down as it checked the object color and this checking correspond to a color frequency with a custom made function that helps to identify the color of the object. The top servo ensure a piece of object is delivered after the object color is identified, which it moves the object from the source to the color sensor, then to the dropping hole with a slider platform handle by a bottom servo. This slider platform is then set in order to deliver the object to the group container where the colored object store.

This Arduino color sorter project is applicable in organizing small objects considering the capabilities of the hardware that drives this project. Aside of organizing the small objects based on color, it is also a good reference for developing larger system that able to sort larger objects especially in industries. Color Based Product Sorting has a wide usage in industries such as fruit sorting, candy sorting, rice, grain, nuts color sorting.

BLOCK DIAGRAM:

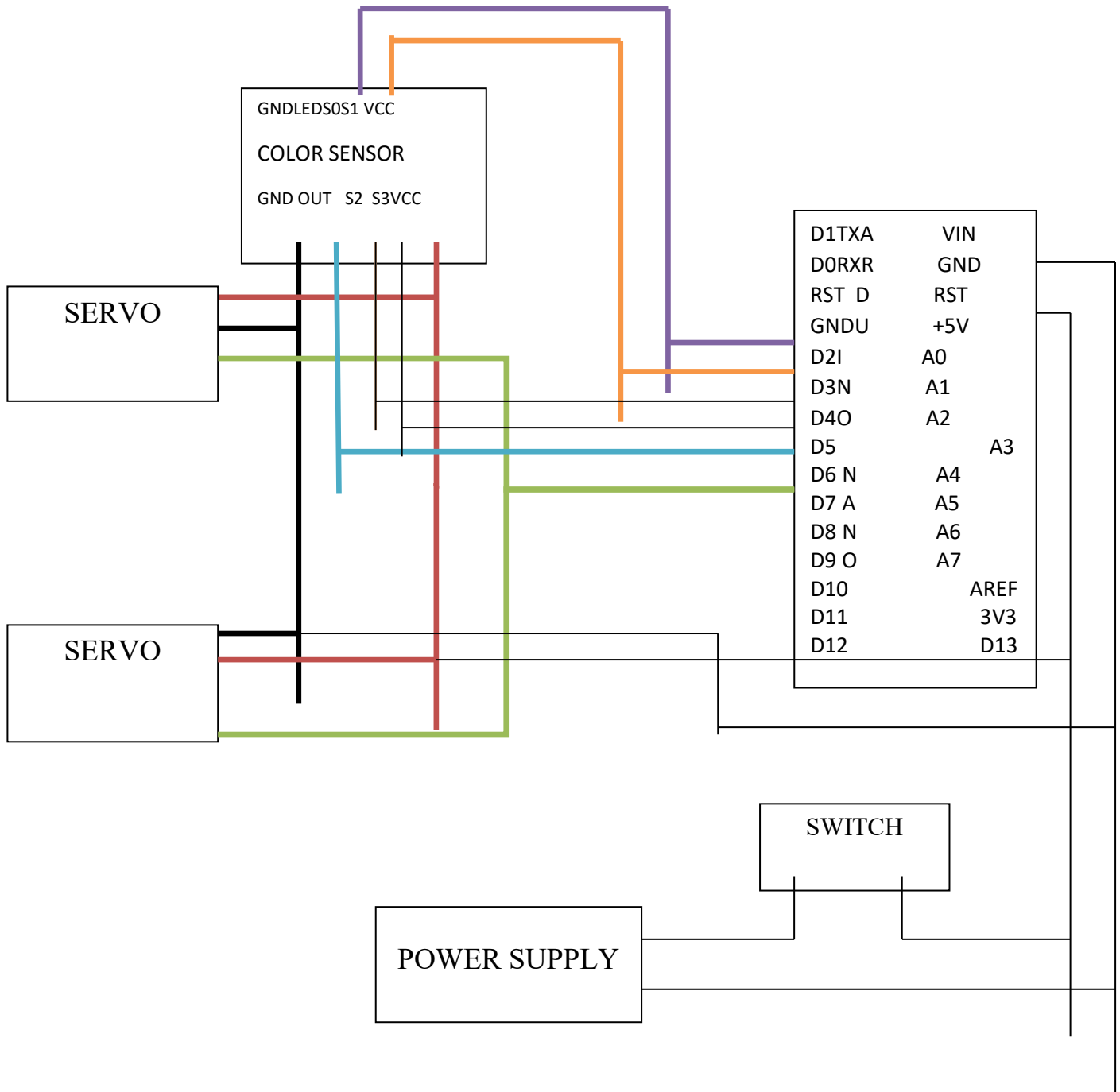

HARDWARE COMPONENTS:

1. Arduino Nano
2. TCS230 TCS3200 Color Sensor
3. Servo Motors -2
4. DC Power Female plug Jack Adaptor
5. Switch
6. Power Supply, Bread board and Jumper cables.

40. Automatic toll collection system using RFID

Abstract: Automatic Toll Tax systems have really helped a lot in reducing the heavy congestion caused in the metropolitan cities of today. It is one of the easiest methods used to organize the heavy flow of traffic. When the car moves through the toll gate on any road, it is indicated on the RFID reader that it has crossed the clearing. The need for manual toll based systems is completely reduced in this methods and the tolling system works through RFID. The system thus installed is quite expedient reducing the time and cost of travellers since the tag can be deciphered from a distance.

The RFID tag is used as a unique identity for account of a particular user. In beginning, the user is prompted to scan his tag or ID. The serial code of the tag is identified by the reader module and is sent to ATmega16 for comparison with stored data. On the contrary, if the tag is not identified, a message ('Wrong ID') is displayed on the LCD screen. The system also shows 'Error' if the tags do not match during verification. If balance in user's account is low, then a message is displayed on LCD screen ('Wrong ID Please Pay in Cash') and the user needs to get recharged the RFID card afterwards.

41. Brain tumor classification from MR Images using neural networks and central moments

Abstract: Now-a- days, the entire world is suffering from one of the deadly disease "Brain Tumor", which leads to death within few days of infection. So far in our country one million people died because of lack of awareness on this disease. There are many methods proposed so far to detect this deadly disease but these are available only for rich people not for poor people. In this project to protect the life of humans, who became the victims of "Brain Tumor", a novel method is invented for the classification of Magnetic Resonance (MR) images of the brain.

This uses database which is composed of a set of MR images of brain trained by several types of brain tumors. There are three processing steps involved in this method. They are preprocessing step, extraction step and the classification step.

Keywords

Magnetic resonance image, medical images processing, brain tumor, central moments, neural networks.

42. Digital Weather Station

This endeavor chooses the continuous condition checking and examination which is a basic research an area of IoT (Internet of Things). Understanding the direct of the astounding organic framework requires examination of point by point impression of a circumstance over a degree of various conditions. One such perspective in urban regions unites the examination of tree shade cover over the microclimate condition utilizing heterogeneous sensor information. There are a couple of troubles that ought to be tended to, for instance, getting strong and separated observations over watching district, perceiving impossible to miss occasions from information, and envisioning occasions progressively by following the areas utilizing GPS module in a way that is effortlessly sensible by the end clients (e.g., City Councils). In such way, we propose a fused revisualization framework, worked for consistent remote sensors like temperature and humidity sensor, rainfall detecting sensor, soil moisture sensor, CO₂ sensor, LDR sensor etc.,, organize data on the coordinated effort of computational information and visual methodologies, to analyze complex models of urban microclimate. A Bayesian most outrageous entropy based system and a hyper ellipsoidal model based count have been work in our consolidated structure to address above troubles

43. Microstrip Patch Antenna with E-Shaped Slot For Dual Frequency In Wireless Applications

Abstract: The Aim of this project is to design an antenna for wireless applications. A micro strip antenna (also known as a printed antenna) usually means an antenna fabricated using micro strip techniques on a printed circuit board (PCB). It is a kind of internal antenna. They are mostly used at microwave frequencies. An individual micro strip antenna consists of a patch of metal foil of various shapes (a patch antenna) on the surface of a PCB (printed circuit board), with a metal foil ground plane on the other side of the board. Most micro strip antennas consist of multiple patches in a two-dimensional array. The radio frequency current is applied (or in receiving antennas the received signal is produced) between the antenna and ground plane. Micro strip antennas have become very popular in recent decades due to their thin planar profile which can be incorporated into the surfaces of consumer products, aircraft and missiles, their ease of fabrication using printed circuit techniques, the ease of integrating the antenna on the same board with the rest of the circuit, and the possibility of adding active devices such as Microwave integrated circuits to the antenna itself to make active antennas.

A compact, wideband micro strip patch antenna with a E-shape slot for dual frequency. The proposed antenna operates at 1.95 GHz and 2.93 GHz bands. The antenna size is very compact (40 mm x 60 mm x 1.6 mm) and is fed from a 50 Ω micro strip line. Using HFSS software, according to the set size, the antenna is simulated. The computer simulation results show that the antenna can realize wide band characters. The proposed antenna has a compact size of (40 mm x 60 mm x 1.6 mm) and it can effectively cover the AMPS, GSM and WLAN applications.

Keywords

Micro strip antenna, E-shape slot, dual frequency, micro strip line, HFSS software.

44. Obstacle Detection On Railway Tracks

Abstract:

Title of the project work: OBSTACLE DETECTION ON RAILWAY TRACK is one of the primary medium of transport in India. Everyday approximately 10.8 million passengers traveling by train. So, the safety of the passengers has to be ensured. The proposed railway system is fully automated using GSM and PIR sensor. It can be operated only by an authorized user and the communication system will run before the train to detect the obstacle. All the information such as the operator of the engine, current location of the communication system, and the distance values between the train and obstacle spot will be updated to related authorities. Based on the received data, triggering actions will be performed. If it finds any obstacle, then the system will stop. And there after using trigger and react option an automated message .The train can be stopped to avoid accident.

This project is to find obstacles on railway tracks in which we used PIR sensor and Arduino. PIR sensor detects the obstacles and gives the information to the microcontroller i.e., Arduino which then checks the condition and displays on LCD and sends a message to the related authorities through GSM.

Block Diagram:

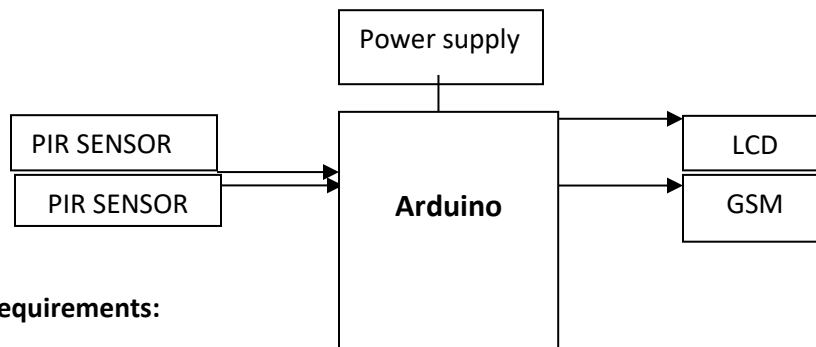

Hardware requirements:

- Arduino
- PIR sensor
- LCD
- GSM

Software requirements:

- Arduino IDE
- Embedded C

Advantages:

- Smart and secure.
- Detection of faults without human interface.
- Avoids accidents.

Applications:

- Used to detect the cracks railway tracks.
- Military purposes
- Delivery services
- Transportation systems
- Blind assistive

45. Paralysis Patient Monitoring

Abstract: We come across hospitals and NGO's serving paralytic patients who have their whole or partial body disabled by the Paralysis attack. These people in most cases are not able to convey their needs as they are neither able to speak properly nor do they convey through sign language due to loss in motor control by their brain. In such a situation we propose a system that helps disabled person in displaying a message over the Voice Playback Module by just simple motion of any part of his body which has motion abilities. Our proposed system works by reading the tilt direction of the user part. The working of the device here is shown by holding in the fingers of the mobile hand. The user now just needs to tilt the device in a particular angle to convey a message. Tilting the device in different directions conveys a different message. Here we use accelerometer in order to measure the statistics of motion. It then passes on this data to the microcontroller. The microcontroller processes the data and displays the particular message as per input obtained. The microcontroller now associated instruction on the Voice Playback Module. In this way the Automated Paralysis Patient Care System truly automates the care taking ability of the patient which ensures a timely attention to the patient and thus for a good health of the patient.

BLOCK DIAGRAM:

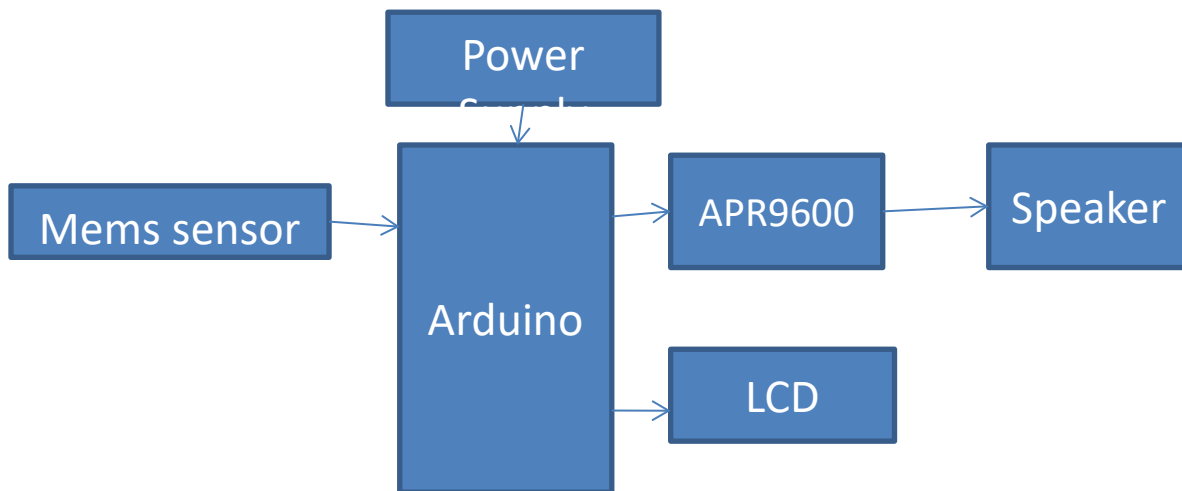

SOURCE CODE:

```
Int v0 = 2;

Int v1 = 3;

Int v2 = 4;

Int v3 = 5;

Void setup () {

    // put your setup code here, to run once:

    Serial. Begin (9600);

    Pin Mode (v0, OUTPUT);

    Pin Mode (v1, OUTPUT);

    Pin Mode (v2, OUTPUT);

    Pin Mode (v3, OUTPUT);

    Digital Write (v0, HIGH);

    Digital Write (v1, HIGH);

    Digital Write (v2, HIGH);

    Digital Write (v3, HIGH);
```

46. Patient Monitoring

Abstract: Nowadays Health-care Environment has developed science and knowledge based on Wireless-Sensing node Technology oriented. Patients are facing a problematic situation of unforeseen demise due to the specific reason of heart problems and attack which is because of nonexistence of good medical maintenance to patients at the needed time. This is for specially monitoring the old age patients and informing doctors and loved ones. So we are proposing a innovative project to dodge such sudden death rates by using Patient Health Monitoring that uses sensor technology and uses internet to communicate to the loved ones in case of problem's. This system uses Temperature and pulse rate sensor for tracking patient's health. Both the sensors are connected to the Arduino-UNO. To track the patient health micro-controller is in turn interfaced to a LCD display and Wi-Fi connection to send the data to the web-server (wireless sensing node). In case of any abrupt changes in patient pulse-rate or body temperature alert is sent about the patient using IoT. This system also shows patients temperature and heartbeat tracked live data with timestamps over the Internetwork. Thus Patient health monitoring system based on IoT uses internet to effectively monitor patient health and helps the user monitoring their loved ones drom work and saves lives.

47. Real Time Monitoring Of Water Quality In IoT Environment

Abstract: In order to ensure the safe supply of the drinking water the quality needs to be monitor in real time. We design a project for the development of a low cost system for real-time monitoring of the water quality in IOT (internet of things).The system consist of several sensors is used to measuring physical and chemical parameters of the water. The parameters such as temperature, PH, turbidity, conductivity, dissolved oxygen of the water can be measured. The measured values from the sensors can be processed by the microcontroller. The ARDUINO model can be used as a microcontroller. Finally, the sensor data can be viewed on internet using IOT.

Nowadays drinking water is the most precious and valuable for all the human beings, drinking water utilities faces new challenges in real-time operations. This challenge occurred because of limited water resources growing population, ageing infrastructure etc. Hence therefore there is a need of better methodologies for monitoring the water quality.

BLOCK DIAGRAM:

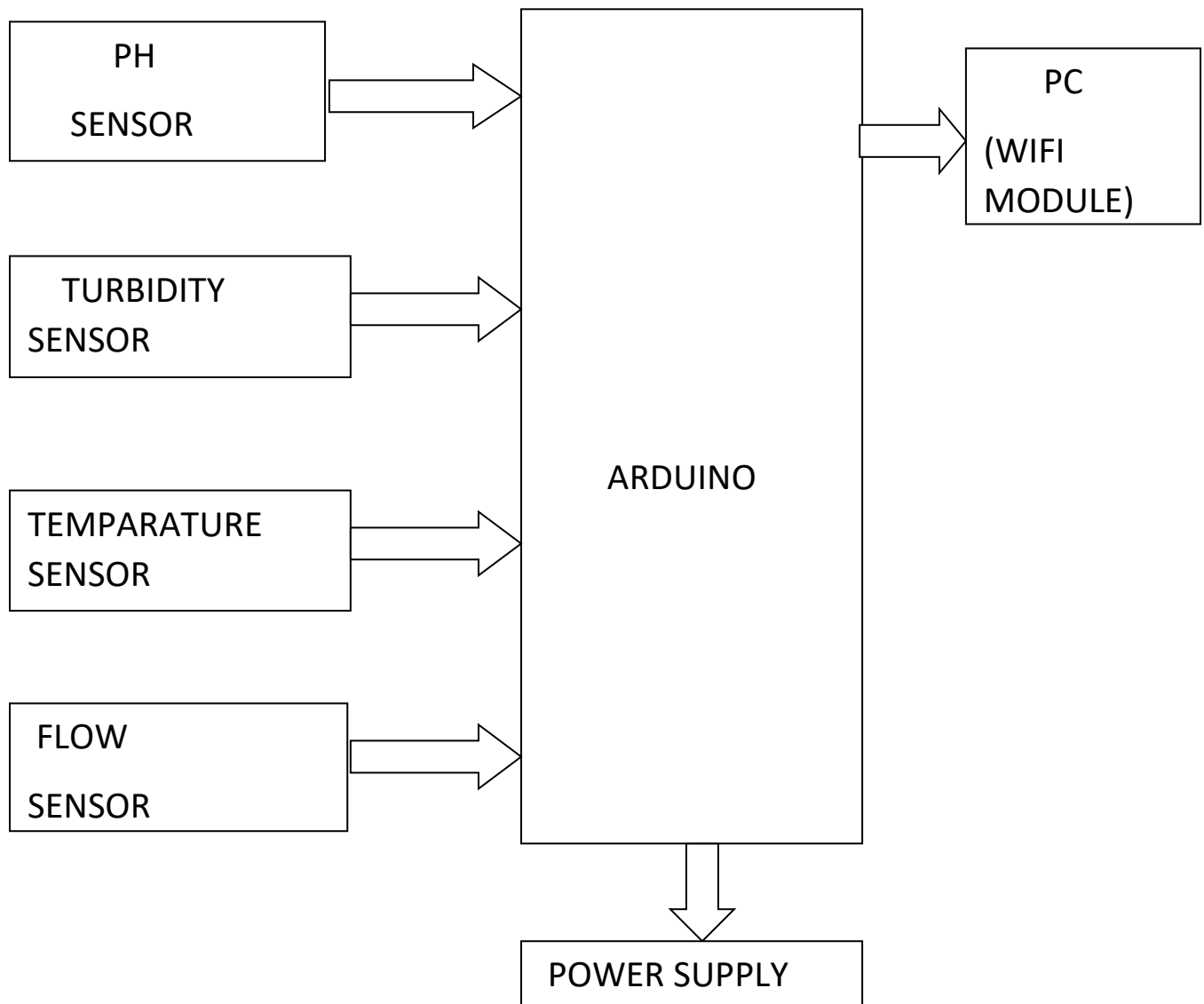

48. Soldier health monitoring and GPS position tracking system

The soldier Health and Position Tracking System allows military to track the current GPS position of the soldier and also checks the health status including body temperature and hearth beat of soldier.

Nowadays, the security system of the nation depending upon the enemy's war and so the security of the soldiers is considered as an important role in it. Concerning the safety of the soldiers, there are numerous tools to observe the health condition as well as bullets on the soldiers. The proposed system uses temperature sensor to status of the body temperature and pulsed rate of the soldier. In this we are using GPS to track the direction of the soldier in the form of latitude and longitude values. GSM is used to send the soldier location to authorized person.. Processing of a collected data using Arduino controller. The system is very helpful for getting health status information of soldier and providing them instant help.

BLOCK DIAGRAM:

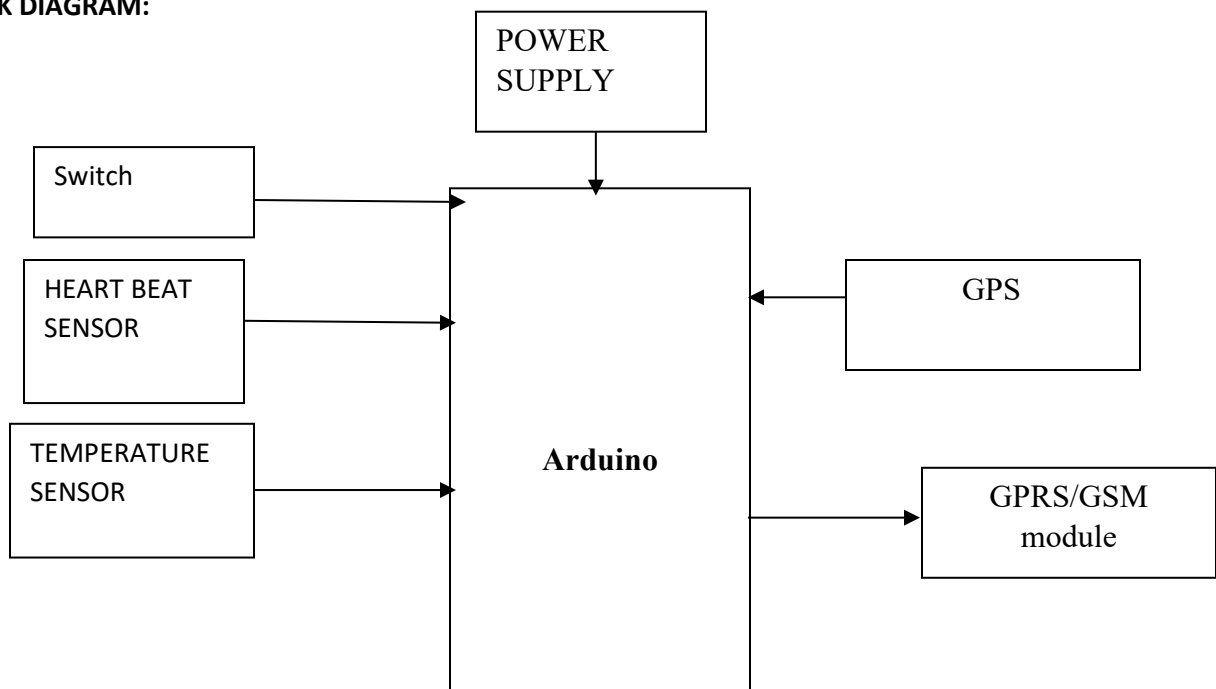

49. Smart Crop Management System

Introduction: Agriculture is boon to the society obtaining the expected crop is an essential thing for farmers. Securing the cultivated crop for Harvesting is so important; crop can be damaged by some natural calamities, due to some wild animal activities.

Problem identification: So to protect the crops from wild animals humans are employing some ways in which there exists threatening of animals or sometimes farmers themselves are attacked by animals. To reduce the risks of damages to the crops as well as conflicts between humans and wild animals, the smart crop management System can be Used.

Innovation: This smart crop management system consists of an UAV which is installed with “Acoustic Sound Generating System”, which makes them feel uncomfortable and makes them to get repelled out of the farm.

About the model: The UAV will be semi-automatic, can be controlled from ground. The flight plan will be uploaded to the UAV, so that it will cover the farm within less time autonomously without human control. The model consists of an onboard camera which can be used for real time monitoring of the crop.

Working: The UAV will Move Autonomously on the Field using its way point navigation system onboard. While it's going Airborne the air unit comprises of a sound system, which generate acoustic sounds that will repel the wild animals, since animals are sensitive to abrupt sound and light it will make them uncomfortable.

Conclusion: With the help our system it is possible monitor the crop, and also effective in keeping the wild animals away from the farm, hence the yielding from crop can be harvested without human animal conflicts can be minimized.

50. WEAPONOBOT

Introduction

It is difficult to monitor and gain control on a remote region at the border regions with discomfort of whether at all the time. Hence there might be a chance in which enemies will enter through the protected border of the Nation. Due to this sudden invasion, many soldiers have lost their lives in the combats while protecting the border. So, we thought of an innovative solution as newly designed “Weaponobot” which is capable of using a weapon if it's necessary to establish peace.

About the model

Weaponobot is an unmanned ground vehicle which is compatible to all terrain and combat regions, it establishes peace and control without causing life loss to the soldiers, it is effective in identifying and warning the enemies at first and also capable of using weapon when situations goes wrong, to gain control over the enemies.

Novelty

So, if we manage to keep weaponobots along with the soldiers or we can replace a soldier, it ensures the safety of our nation by working relentlessly. It can be controlled remotely which is far from the base control station by the commander or chief, the real time parameters from the robot of the surroundings, status of the robot and the live feed can be obtained at the base control station itself through the telemetry.

Conclusion

The robot is a remotely operated UGV integrated with an on board weapon. This technology in defence sector is been introduced but the concept of integrating weaponry is not yet put into action especially in

the armed forces of India. Hence we can save the lives of soldiers without compromising to the surveillance and control and rescue operations can be performed with these robots.

51. Medical Innovation using AI

Abstract: Dementia, a disease where people tend to lose neurons in their brains which ultimately causes a loss of memory. The age factor of about 75 or older tends to have a high risk prone to this disease. The chances of regenerating neurons at that age are highly not conclusive.

Research states that the loss of neurons occurs in the **Hippocampus**, an important part of limbic system.

There are few cures which can be done, i.e., Stem Cells, Immunotherapy.

So, resolving to another idea through which the possibility of curing the disease would be efficient-

Developing a device which is capable of detecting the portion where there's loss of neurons inside of hippocampus would help neurologists to implant new brain cells.

With the advance developments in **AI** and an increase in demand for **Neural Networks**, we create two oval bands built with EEG sensors which would stick to either sides of our forehead. The images inside the brain are clearly viewed on a monitor with the help of Augmented Reality and CGI which would preview the images in three dimensional formats.

The monitor enabled with **Deep Learning** (DL) here is designed in a way which would synchronize the brain's electrical impulses and gives an output in an imagery format to carry out further treatments by neurologists.

As being humans we desire all the things which lure us to sights, this shouldn't be just limited to a certain age groups. The elder people do deserve to enjoy their last bits of life irrespective of all diseases.

And the results are worth to witness.

52. Power Generation Using Kinetic Energy from Vehicles

Abstract: Energy generation has seen significant development in recent years. This investigation describes a new technique for generating energy from the waste kinetic energy of the vehicles at low speed. A complete description of the system is presented including the general concept, configurations, mechanical design, and electrical system. The system based on the principle of drum rotation due to low movement or transportation of the vehicles driven at low speed at different places such as moles, hotels, universities entrance and fast meals gates.

The results show that this new technology could provide an efficient and low-cost method of generating electricity from vehicles and the generated electricity has been utilized for different types of applications and mainly for street lighting, domestic uses such as air conditioning, lighting, heating. Some major factors have been studied and practically designed and tested such as there is no possibility to failure or yielding of shaft under loading and the drum is more strength to bending and other forms of stress. It was found through this work that the generated electricity of system and under Jordanian climate conditions can be utilized for electrical and the vehicles waste kinetic energy is one of the renewable sources of energy which can be harnessed to generate electricity. This system depends on

the vehicle's weight, when the weight increases the rpm of the drum will increase. As the horizontal vehicle speed is increased the rotational speed of the drum will be increased.

It was found that the effective rotational drum speed ($n = 35$ rpm) at which the system starts to charging. The friction between the tire and the drum increases when the vehicle weight increases. The reported results indicated that we need only about 10% of vehicle attractive effort to generating a sizable amount of electrical energy. Also, the testing results proven that the minimum effective vehicle's speed is 20 Km/hr, this means that all of the vehicle going over the system can be harnesses to produce the energy. The suggested model will be able to generate energy may be economically feasible to use for a larger application, and thus helps to reduce the costs of energy production. On the practical side we have been able to produce and store electrical energy using this model at minimum speed of 20 km/hr, and the system is considered simple to install, inexpensive compared with other sources, safe, and has no bad impacts on the environment. Also, the system can be modified and subjected to upgrading. The system total cost was found to be about US \$900 and this is an extra motivation to use this system.

Keywords

[Harvesting; Waste Energy; Vehicle; Generator; Kinetic Energy; Electrical Power; Drum](#)

53. Corn Used As A Bio-Fuel

Abstract: Corn (*Zea mays*) is a popular feedstock for ethanol production in the United States due to its abundance and relative ease of conversion to ethyl alcohol (ethanol). Corn and other high-starch grains have been converted into ethanol for thousands of years, yet only in the past century has its use as fuel greatly expanded. Conversion includes grinding, cooking with enzymes, fermentation with yeast, and distillation to remove water. For fuel ethanol, two more steps are included: using a molecular sieve to remove the last of the water and denaturing to make the ethanol undrinkable.

Corn in the upper Midwest is seeded between March and May and harvested between September and November in most years. A majority of corn planted today has genetic resistance to some weeds, insects, and plant pathogens. Corn hybrid resistance to various pests and pathogens is a result of biotechnology and plant breeding. Biotechnology traits aid producers in the control of weeds and insects, greatly reducing the amount of pesticides entering the environment (Brookes and Barfoot, 2006). Much of the Corn Belt rotates with other crops, such as soybeans or wheat, to break weed, insect, and disease cycles as well as to reduce the cost of production. Corn responds best to highly fertile soils with supplemental fertilizer applied in most years. Fertilizer may be inorganic chemical fertilizer or manure.

Major nutrients required by corn are nitrogen, phosphorus, and potassium. Inorganic nitrogen fertilizer production is very energy-intensive and as a result, nitrogen fertilizer represents nearly 30% of the energy inputs in corn production (BESS, 2009). Other major inputs include diesel fuel for tractors, transportation, irrigation, and electricity for irrigation and grain storage.

Life cycle analysis (LCA) of ethanol production from corn grain has yielded a net energy ratio of 1.2 to 1.45 (Liska et al., 2009), which represents just a 20% to 45% positive energy balance in producing ethanol from corn. A major criticism of corn ethanol has been the large amount of fossil energy used in production.

Environmental issues in corn production revolve around erosion, pesticide use, and nutrient use. Pesticides and nutrients have the potential to contaminate surface and ground water. Soil erosion has led to loss of topsoil and polluted streams and river systems with silt. Continuous attention to these issues has led to improvements, yet they will remain concerns in crop production.

Innovation in the process:

Corn fuel is nothing but the waste corn can be converted into useful Bio-fuel. Firstly the waste corn is dried in a sun light for two days. After that the waste corn makes into small pieces then mixed into powder by using mixi grinder. Then, this powder mixed with starch. This wet corn powder cleaned by using sulphuric acid (H_2SO_4) and acetic acid through a big injection. In this process the element lignite is removed.

After that these wet corn powder mixed with ester and starch powder. This mixed composition of corn powder stored in a dark room for a one night. After next day morning add some ester and starch powder make into small balls to this composition. These balls dried for some time. The corn fuel has high calorific value than coal. It burns very quickly. After burning, the ash can be used for improving the fertility of soil for farming.

Benefits

- Non Pollution
- Cost benefit
- Easy to source
- Renewable
- Reduce greenhouse gases
- Reduce dependence on Foreign Oil

54. Amazon

Abstract: Looking upon the current situations prevailing around the world, women have to face many problems regarding their security. Insecurities increase when she travels or walk alone along the road. Everyone wants their girls to reach home safely. Consider a scenario when your girl didn't reach home on time. You may get eager to know about her safety. Whether she is okay, in trouble, or had an accident. Things get even worse if you do not know where your girl currently is. You must know the location in that scenario as well. Technologies are change but still the women are hesitating to go out and build their career. Due to this they don't have their freedom.

To overcome such fears how about having a device that keeps a track of your girls while they are outside. Women's safety device with GPS tracking and alerts using a push button is the best solution to the problem. This will provide you with the location of your girl when she wants. Moreover, women can send their current location to their family when outside to prevent any mishap. This device proves to be very useful in preventing women's harassment incidents. The push button feature available in the device where the person is in trouble then it gives the message to the kit and it passes the message to the particular mobile numbers.

By selecting the proper low power GSM & GPS Module (AG9 GSM + GPRS + GPS Module). This device is very small, fix anywhere and it is operated using small 3.7 Lithium-Ion Battery. The Board has 32-bit ATSAMR controller from Atmel which can be programmed using Arduino IDE.

After programming the board via Arduino IDE, the board will take some time for retrieving location by fixing the GPS coordinates. You can request the location by sending the message like typing a word Location. Within a while, you will receive an SMS along with the Google Maps coordinates.

Benefits

1. Best for women security
2. Keeps alert
3. Helps to keep safe from violence
4. Location tracking becomes easy
5. Avoid panic situations to parents